

## ORDERING CODE 订购代码

HLS-4121- H - DC12V - NS

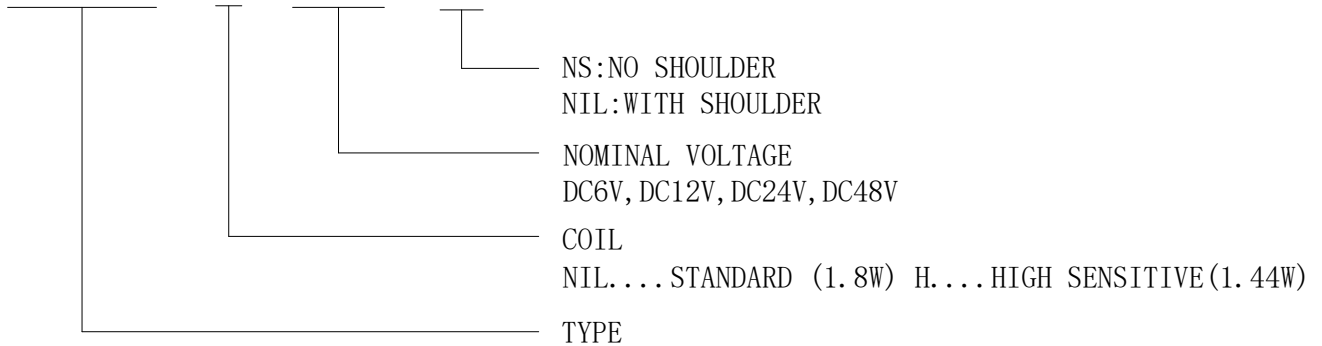

## CONTACT DATA 触点参数:

Contact Form	触点形式	1A
Contact Material	触点材料	Ag Alloy
Contact Ratings	触点负载	30A14VDC
Max Switching Voltage	最大转换电压	30VDC
Max Switching Current	最大转换电流	300A
Max Switching Power	最大转换功率	420W
Initial Contact Resistance	接触电阻 (首次)	50mΩ Max at 6VDC 1A
Life Expectancy Electrical	电气寿命	100,000 Operations (rated load)
Life Expectancy Mechanical	机械寿命	10,000,000 Operations (no load)

## GENERAL DATA 一般参数:

Insulation Resistance	绝缘阻值	50MΩ min at 500VDC
Dielectric Strength Between Open Contacts	触点间耐压	500VAC 50-60HZ (1 minute)
Dielectric Strength Between Contacts And Coil	触点与线圈间耐压	500VAC 50-60HZ (1 minute)
Operate Time	吸合时间	10ms max
Release Time	释放时间	10ms max
Ambient Temperature	环境温度	-30°C to +85°C
Shock Resistance	冲击	10G
Vibration Resistance	振动	10-55Hz, 1.5mm double amplitude
Ambient humidity	湿度	40-85% RH
Weight	重量	Approx 35g
Safety Standard	安全标准	

**COIL DATA 线圈参数: (@20°C)**

Rated Voltage 额定电压 (VDC)	Coil Resistance $\Omega$ ( $\pm 10\%$ ) 线圈阻值		Max Operate Voltage 最大吸合电压 (VDC)	Min Release Voltage 最小释放电压 (VDC)	Max Applied Voltage 最大允许电压 (VDC)
	1.44W	1.8W			
6	25	20	3.9	0.6	7.8
12	100	80	7.8	1.2	15.6
24	400	320	15.6	2.4	31.2
48	1600	1280	31.2	4.8	62.4

Outline Dimension 外形尺寸 (mm)

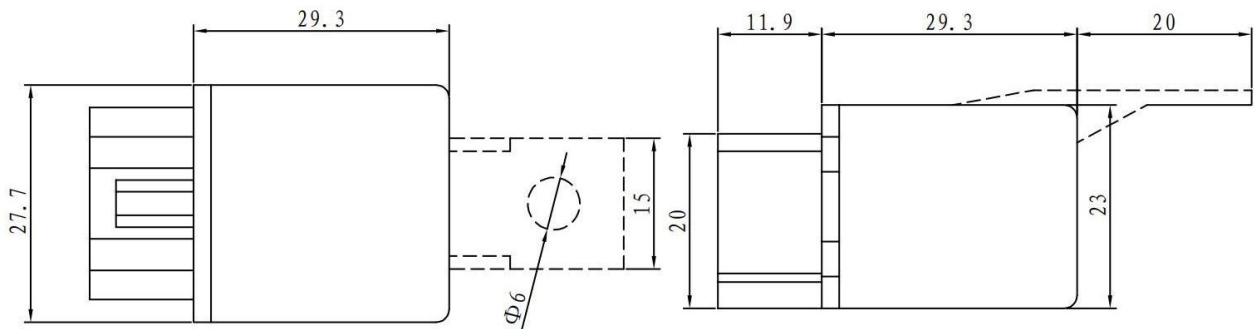

PC Board layout 安装图

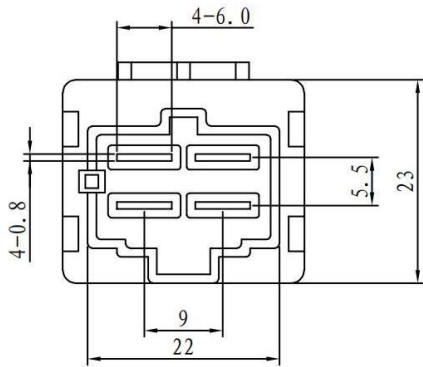

(Bottom View 底视)

Wiring Diagram 接线图

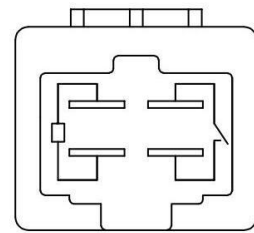

(Bottom View 底视)

声明：本产品规格书仅供客户使用时参考，若有更改，恕不另行通知。

对合力顺而言，不可能评定继电器在每个具体应用领域的所有性能参数要求，因而客户应该根据具体的使用条件选择与之相匹配的产品，若有疑问，请与合力顺联系获取更多技术支持。但产品选型责任仅由客户负责。

©宁波合力顺电子有限公司版权所有，本公司保留所有最终解释权。